



KLCOB V2 Series User Manual



Shenzhen Absen Optoelectronic Co.,Ltd.

Catalogue

1. Product Introduction	- 6 -
1.1 Product Main Features	- 6 -
1.2 Product Specifications	- 7 -
1.3 Cabinet dimension figure.....	- 8 -
1.4 Module dimension figure.....	- 8 -
2. Product Components	- 9 -
2.1 Cabinet Introduction.....	- 9 -
2.2 Product Component Drawing	- 9 -
3. Product Installation.....	- 11 -
3.1 Steel structure installation.....	- 12 -
3.2 Wall mounting installation	- 13 -
3.3 Hanging installation.....	- 14 -
4. Product Cabling	- 15 -
4.1 Power Supply Wiring	- 17 -
4.2 Signal Cable Wiring	- 18 -
4.3 The test of setting up an electric circuit.....	- 19 -
5. Maintenance.....	- 20 -
5.1 Tool preparation.....	- 20 -
5.2 Maintenance instructions.....	- 20 -
6. Common faults and troubleshooting	- 22 -

Safety Information



WARNING!

Please read the safety measures listed in this section carefully before installing, powering on, operating, or doing maintenance on this product.

The following marks on the product and in this manual indicate important safety measures.



WARNING!
Safety risk! Might cause equipment damage or safety risk.



WARNING!
Please read the manual before operating.



WARNING!
Dangerous voltage! Might cause equipment damage or electric shock.



WARNING!
Hot surface! Do not touch.



WARNING!
Flammable!



WARNING!
Possible damage to eyes.



WARNING: Be sure to understand and follow all safety guidelines, safety instructions, warnings and precautions listed in this manual. This product is for professional use only! This product may result in serious injury or death due to fire hazard, electric shock, and crushing hazard.



Please read this manual carefully before installing, powering up, operating and maintenance of this product. Follow safety instructions in this manual and on the product. If you have any questions, please seek help from Absen.



Beware of Electric Shock!

- To prevent electric shock the device must be properly grounded during installation. Do not ignore using the grounding plug, or else there is a risk of electric shock.
- During a lightning storm, please disconnect the device's power supply, or provide other suitable lightning protection. If the equipment is not in use for a long time, please unplug the power cord.
- When performing any installation or maintenance work (e.g. removing the fuses, etc.,) make sure to turn off the master switch.
- Disconnect AC power when the product is not in use, or before disassembling, or installing the product.
- The AC power used in this product must comply with local building and electrical codes, and should be equipped with overload and ground fault protection.
- The main power switch should be installed at a location near the product and should be clearly visible and easily reached. This way in case of any failure the power can be promptly disconnected.
- Before using this product check all electrical distribution equipment, cables and all connected devices, and make sure all meet current requirements.
- Use appropriate power cords. Please select the appropriate power cord according to the required power and current capacity, and ensure the power cord is not damaged, aged or wet. If any overheating occurs, replace power cord immediately.
- For any other questions, please consult a professional.



Beware of Fire!

- Use a circuit breaker or fuse protection to avoid fire caused by power supply cables overloading.
- Maintain good ventilation around the display screen, controller, power supply and other devices, and keep a minimum 0.1 meter gap with other objects.
- Do not stick or hang anything on the screen.
- Do not modify the product, do not add or remove parts.
- Do not use the product in case ambient temperature is over 55 °C.



Beware of Injury!



- Warning: Wear a helmet to avoid injury.
- Ensure any structures used to support, fix and connect the equipment can withstand at least 10 times the weight of all the equipment.
- When stacking products, please hold products firmly to prevent tipping or falling.
- Ensure all components and steel frames are securely installed.
- When installing, repairing, or moving the product, ensure the working area is free of obstacles, and ensure the working platform is securely and stably fixed.
- In the absence of proper eye protection, please do not look directly at the lit screen from within a 1 meter distance.
- Do not use any optical devices that have converging functions to look at the screen to avoid burning the eyes.



WARNING: Beware of suspended loads.



LED lamps used in the module are sensitive and can be damaged by ESD (electrostatic discharge). To prevent damage to LED lamps, do not touch when the device is running or switched off.



WARNING: The manufacturer shall not bear any responsibility for any incorrect, inappropriate, irresponsible or unsafe system installation.



Product Disposal

- Any component that has a recycling bin label can be recycled.
- For more information on collecting, reusing and recycling, please contact the local or regional waste management unit.
- Please contact us directly for detailed environmental performance information.

Warning: Changes or modifications to this unit not expressly approved by the party responsible for compliance could void the user's authority to operate the equipment.

NOTE: This equipment has been tested and found to comply with the limits for a Class A digital device, pursuant to part 15 of the FCC Rules. These limits are designed to provide reasonable protection against harmful interference when the equipment is operated in a commercial environment. This equipment generates, uses, and can radiate radio frequency energy and, if not installed and used in accordance with the instruction manual, may cause harmful interference to radio communications. Operation of this equipment in a residential area is likely to cause harmful interference in which case the user will be required to correct the interference at his own expense.

1. Product Introduction

The KLCOB V2 series is a Micro LED fine pixel pitch LED display dedicated to the control room and conference room. It uses integrated flip encapsulation. The Panel size is 600X337.5mm. It is designed with a 27 -inch 16: 9 ratio and can better display the details of the image.

Product application: professional control room, conference room, studio, high -end business display.



1.1 Product Main Features

Black,Extraordinary deep blacks. The surface is covered with a black coating of polymer material, which brings amazing black consistency, bringing a deep and pure black, which improves the visual performance to an unprecedented level.

Brilliant,Capture every brilliance. Integrating multiple Absen image optimization technology, the KLCOB enhanced the clarity and visibility to bring out natural details and vivid colors for realistic and incredible images.

Cool,Stay cool, enjoy more. Thanks to the flip-chip LED technology and Absen's HBB technology, the KLCOB can always stay cool, diving into the fantastic visual world without breaking a sweat.

Strong,Against external impact. The panel-type Micro LED encapsulation technology effectively protects the display from external impact , providing 360° all-round protection.

Maximize Your View. The KLCOB cabinet adopts a 16:9 display ratio,which can be easily spliced into 2K,4K,8K screens or any size you want,providing an immersive view experience.

Refresh Pair of Eyes. The non-glare surface light source brings softer and uniform light, and the eye fatigue is relieved when watch the screen for a long time.

Perfect in-Camera Performance.Panel-type light-emitting effectively reduce moiré, and has excellent in-camera performance, especially suitable for scenes such as TV studios, lecture halls, etc.

More Quality, Less Consumption. Energy saving is achieved by a combination of four technological innovations.Saving 40% energy under the same conditions, and practice the "Absen Green" concept.

1.2 Product Specifications

Parameter		KLCOB0.7 V2	KLCOB0.9 V2	KLCOB1.2 V2	KLCOB1.5 V2	KLCOB1.8 V2
Physical Parameter	Pixel Pitch (mm)	0.78	0.93	1.25	1.56	1.87
	LED Type	Flip RGB				
	Panel Dimensions (WxHxD)/(mm)	600x337.5x39.3				
	Pixel Per Panel	768x432	640x360	480x270	384 x216	320x180
	Panel Weight (kg)	4.3				
	Panel Material	Die casting aluminium				
	Module Dimensions (WxH)/(mm)	150 x168.75				
Optoelectronic Parameter	Brightness (nit)	600				
	Gray scale (bit)	20bit (internal processing)	19bit (internal processing)	20bit (internal processing)	19bit (internal processing)	19bit (internal processing)
	Refresh Rate (Hz)	3840				
	Contrast Ratio	15000: 1				
	Color Temperature(K)	6500:				
	Viewing Angle (H/V) (°)	160/160				
	Driving Type	1/48	1/54	1/60	1/54	1/40
	AC Operating Voltage (V)	100~240				
	Power Consumption (Max./Avg.)(W/m ²)	390/130	331/110	301/100	336/112	290/97
Application Parameter	Storage Temperature (°C)	- 40~ + 60				
	Operating Temperature (°C)	- 10~ + 40				
	Storage Humidity (RH)	10 % ~85 %				
	Operating Humidity (RH)	10 % ~80 %				
	IP Rating (Front/Rear)	IP40/IP21				
	LED Lifetime (H)	100000				
	Module Maintenance	Front				
	PSU & Others Maintenance	Front				
	Panel Installation Type	Stacking/wall mounting/Hanging				
	Certificate	CE/FCC/ETL/UKCA				

Remark: Power consumption tolerance: ±15%, according to the actual situation.

1.3 Cabinet dimension figure(mm)

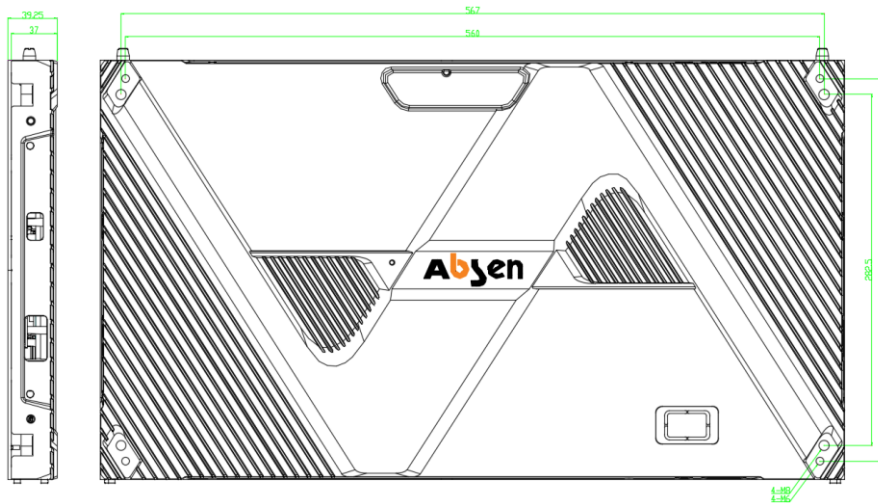

1.4 Module dimension figure(mm)

The module size is 150 x168.75mm,each panel has 8 modules.

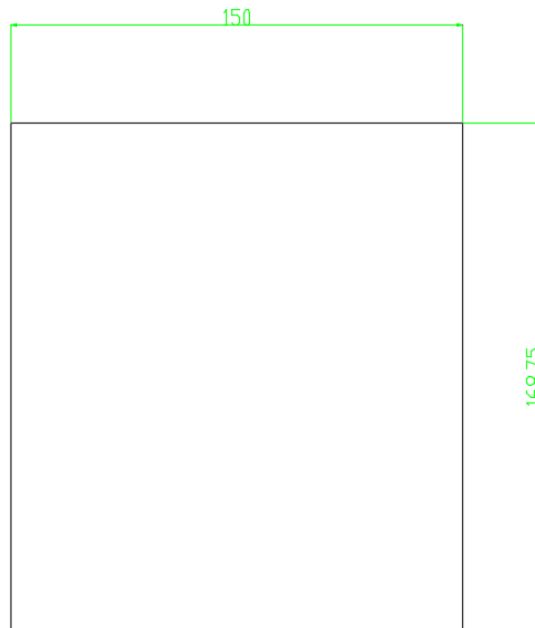

2. Product Components

2.1 Cabinet Introduction

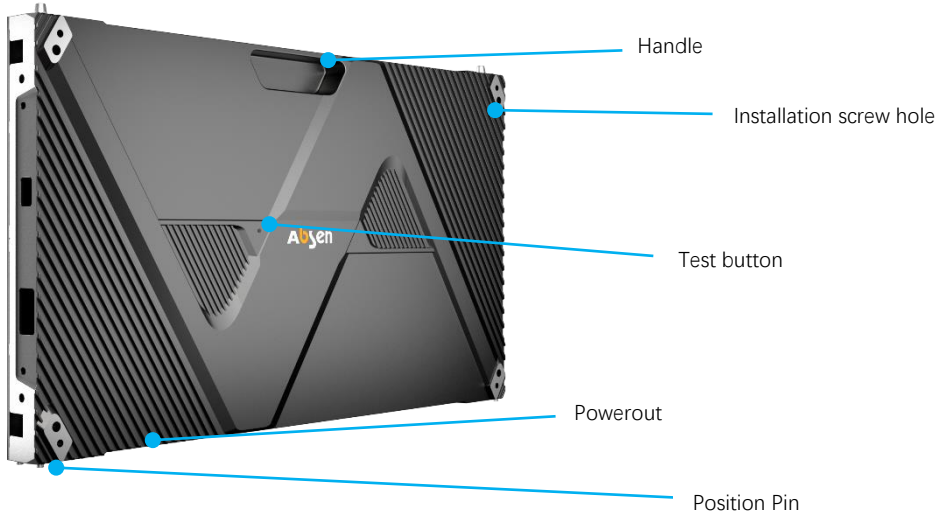

2.2 Product Component Drawing

2.2.1 Mounting frame: used for wall mounting, including single and double frames.

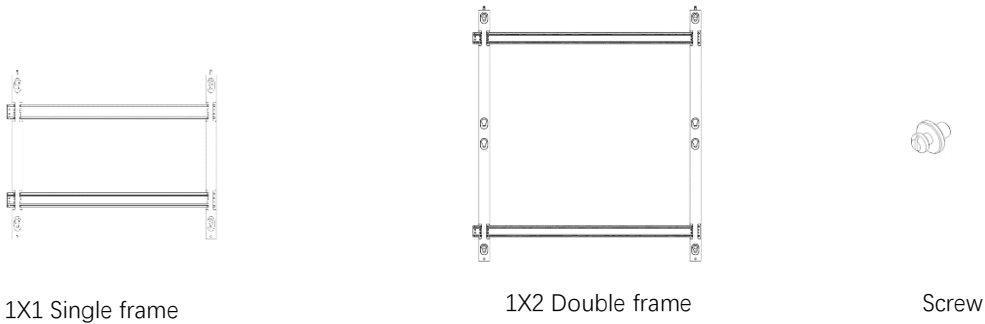

2.2.2 Hanging bar: used for hanging installation ,Including double and triple frame.

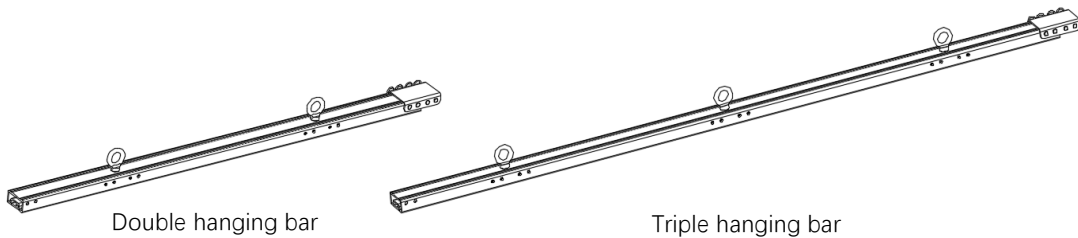

2.2.3 Connector plates and bolts are used for installations with steel structure.

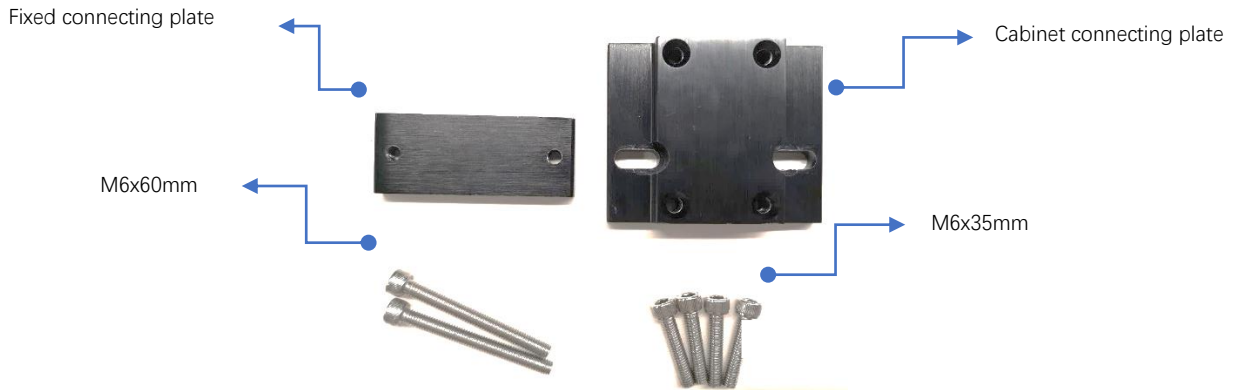

2.2.4 Data Jumper for vertical connections in between cabinets (Standard Version), 300mm long.

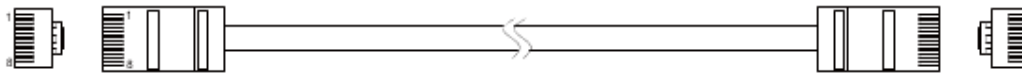

2.2.5 Power cable

Specification: 3x2.5mm², 10m

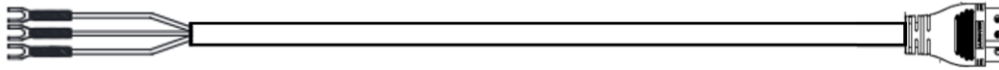

Specification: 3x2.5mm², 0.9m, Used for adjacent column panel connections.

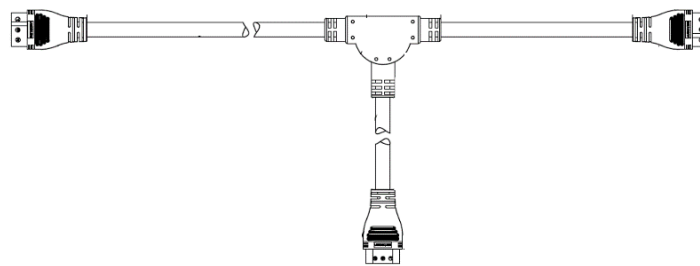

"T" type power cable

2.2.6 The module is separated from the panel, the 1 module carton contains a 48PCS module, and the 1 panel carton contains 6PCS panels

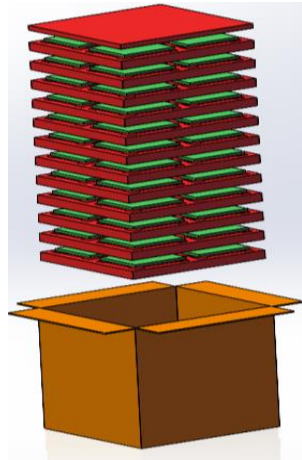

Module 48 -in -1 carton packaging

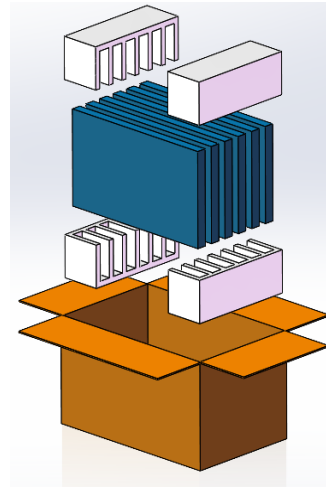

Panel frame 6 -in -1 carton packaging

3. Product Installation

In order to ensure the visual effect, the cabinets and modules need to be installed in the exact position. The rules are as follows:

cabinet number: XX (Screen number) —XX (Row number) —XX (cabinet number)

1-1-1	1-1-2	1-1-3	1-1-4
1-2-1	1-2-2	1-2-3	1-2-4
1-3-1	1-3-2	1-3-3	1-3-4
1-4-1	1-4-2	1-4-3	1-4-4

Front side

Module number : XX (Screen number) —XX (Row number) —XX (Cabinet number) —

XX (Module number)

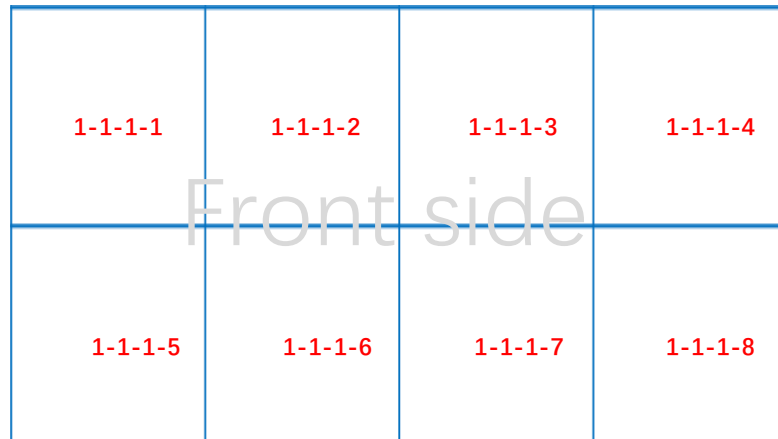

3.1 Steel structure installation

Installation is from the bottom to the upper layer, first lock the connection screw between the panel, and then use the connection piece and the M6x60mm screw to fix it on the steel structure .

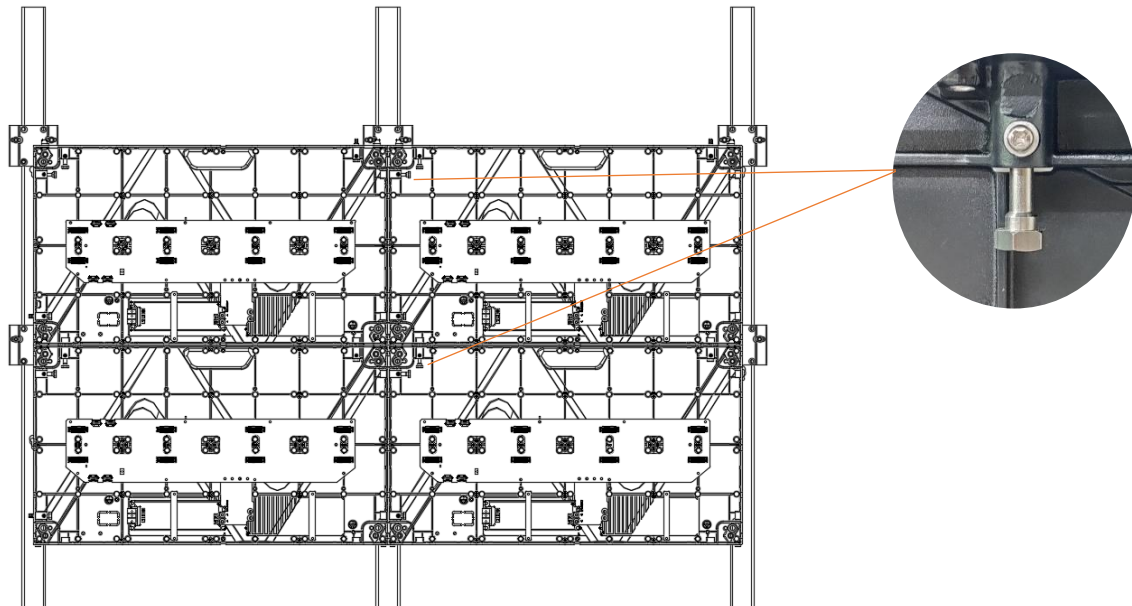

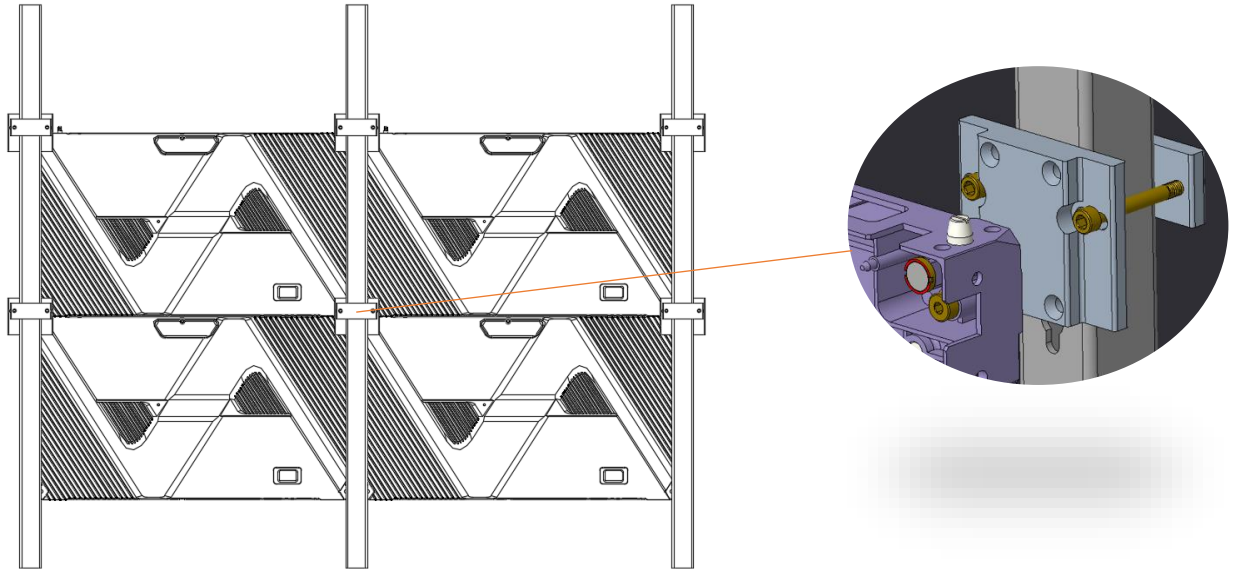

After the panel is installed, confirm that the wire is connected, and then install the module on the frame according to the rule number.

3.2 Wall mounting installation

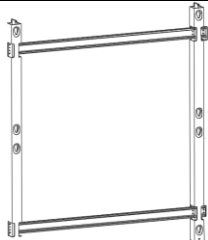
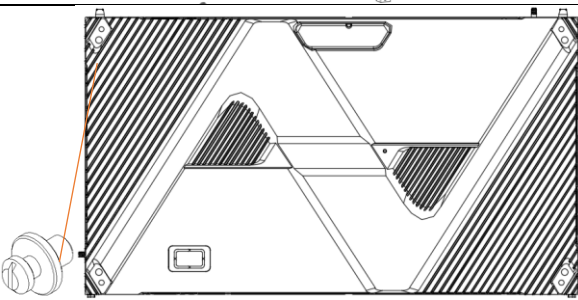
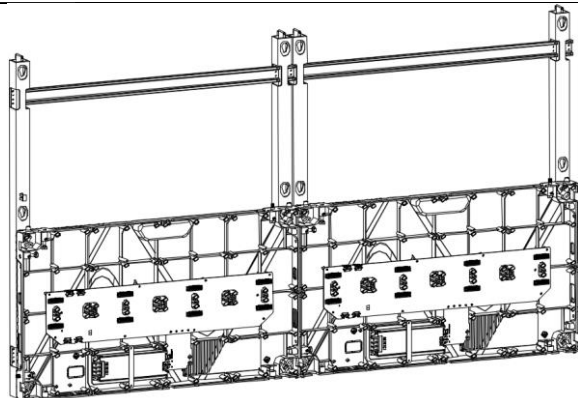
Steps	Diagram
<p>step 1: Use M6 self-tapping screws or M6 expansion screws to fix the wall mounting frame on a flat wall.</p>	
<p>Step 2: Install the screw on the mounting holes, and install 4 screws on each panel .</p>	
<p>Step 3: Install the panel frame (excluding modules) on the wall mounting frame . Install from bottom to top, and complete the installation of the inner connection piece .</p> <p>Note: The left and right sides, top and bottom of the panel are locked and fixed with screws .</p>	

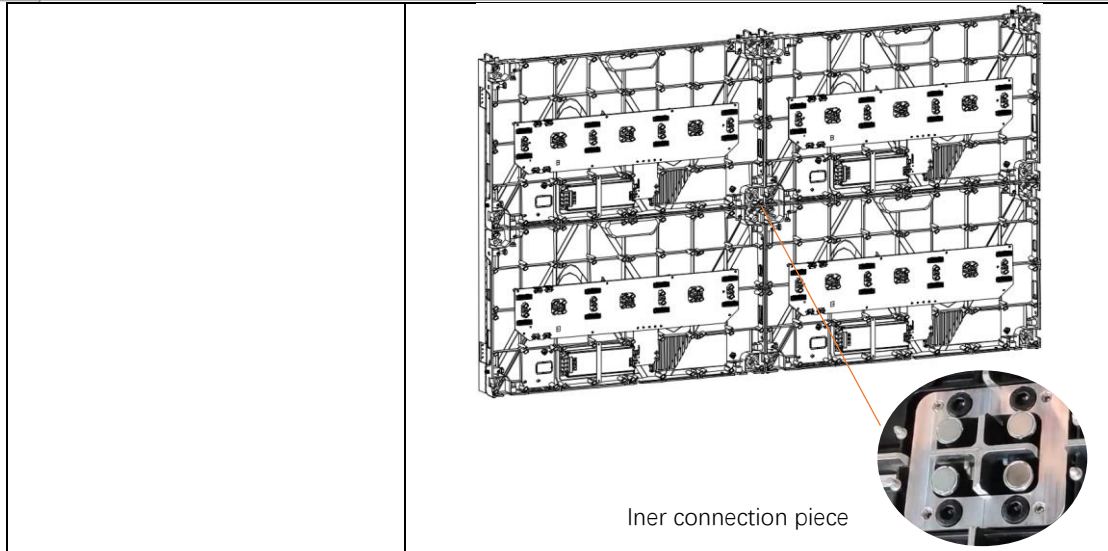

3.3 Hanging installation

Use the screws connenct the hanging bar , The maximum lifting capacity cannot exceed 20 panels,and the inner connection pieces is needed.

Installation steps:

- a. Fixed the hanging bar on the structure .
- b. Align the screw holes of the panel with hanging bar and fixed the panel.
- c. Install other panels, and tighten the screws in four directions .
- d. Install the inner connection picces .
- e. Complete the connection between the network cable and the power cable .
- f. Complete the modules installation .

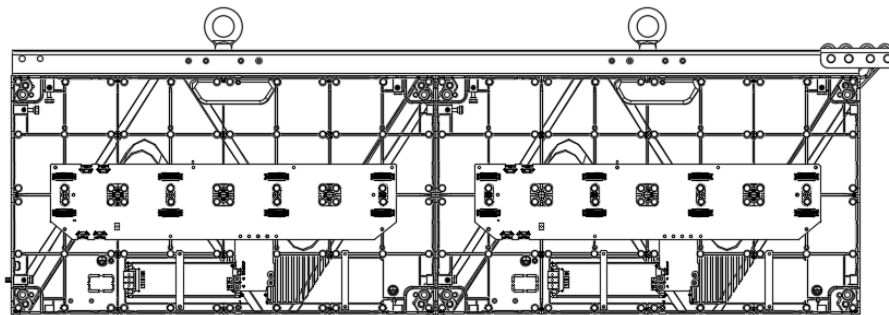

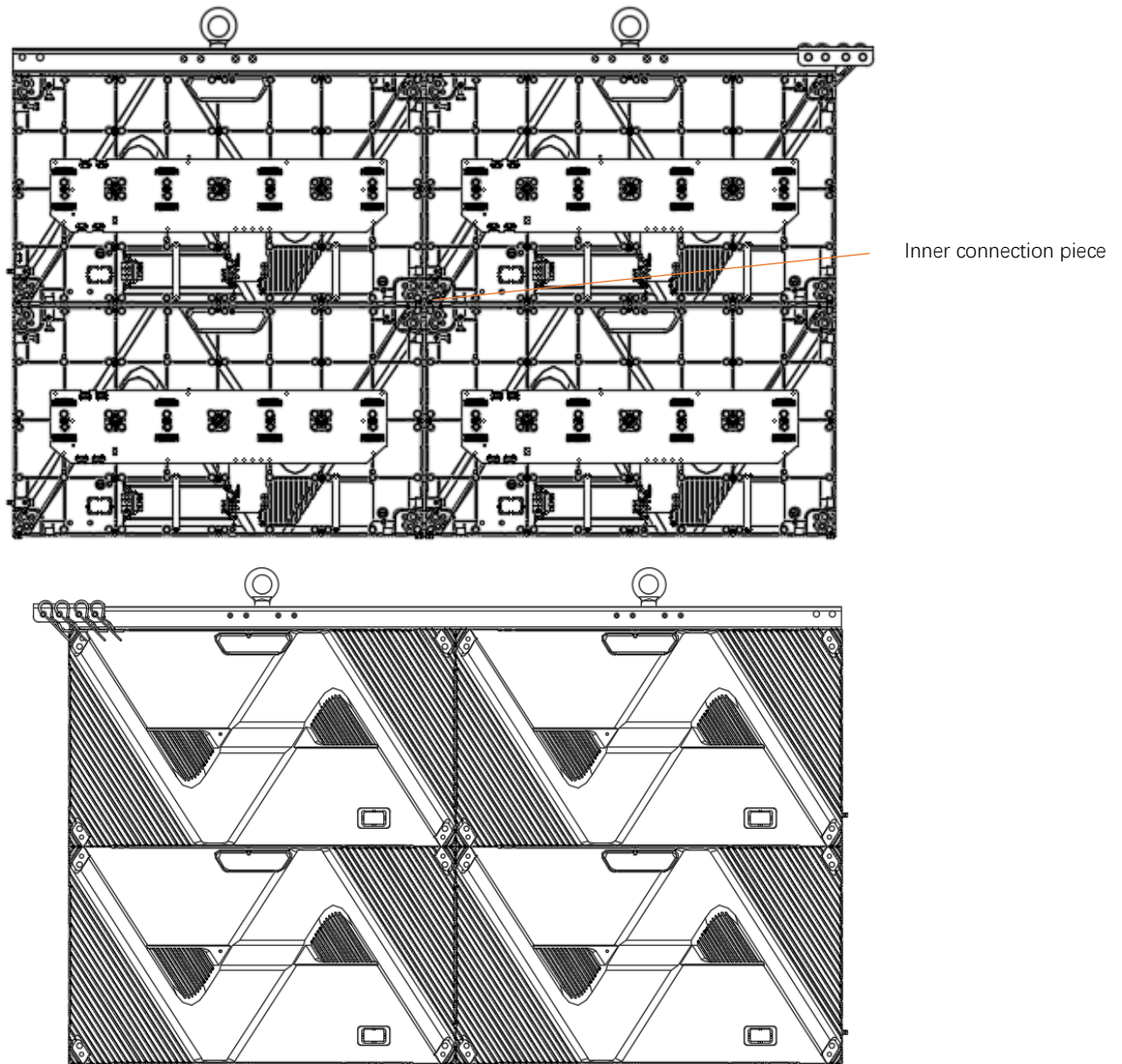

4. Product Cabling

Preparation before cabling

Before applying power and signal source to the screen, please check power and data cables connections carefully and make sure they are wired correctly. Use a multimeter to test the L, N and PE lines in AC power input port and make sure the three lines are not short-circuited.

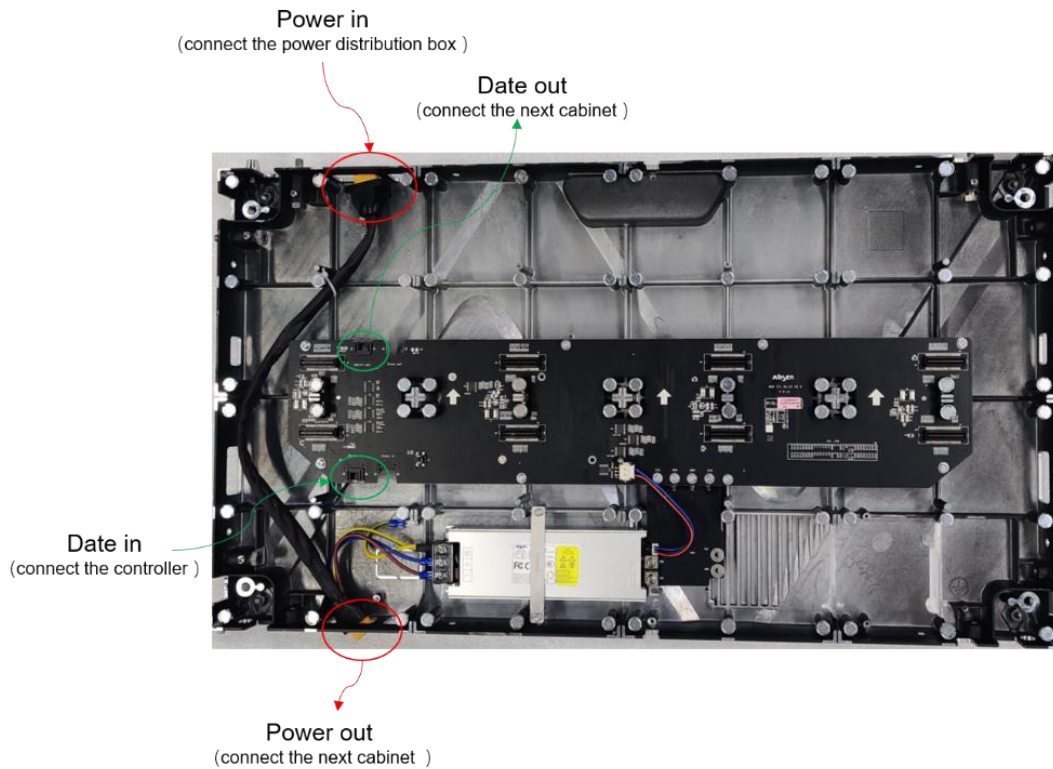

Power and signal connections inside the cabinet

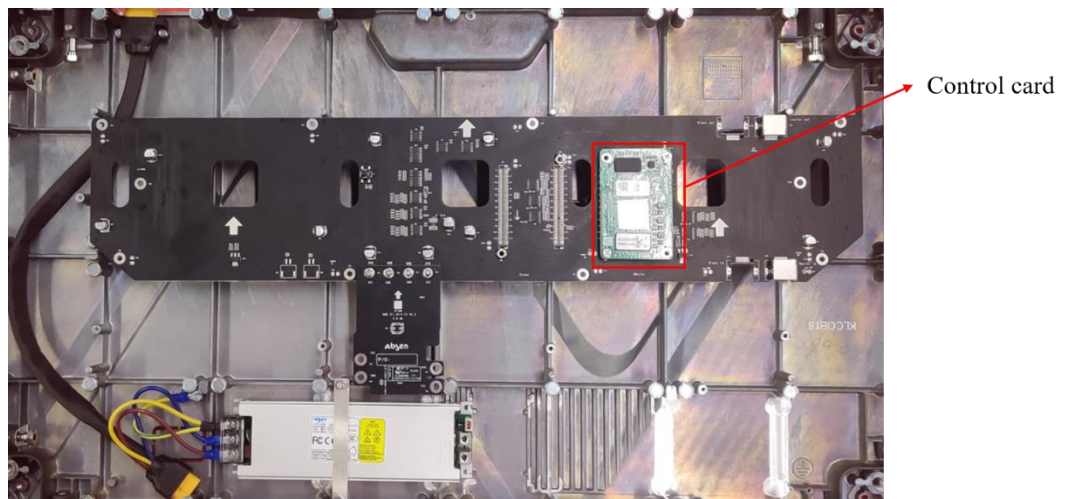

Each cabinet contains a control card (two for backup versions). The control card receives signals from the controller to control each LED pixel. The control card is composed of multiple components, including MCU, memory, interface chips, etc., and can process data, store correction data, and also control the effect of the LED display.

Control card Indicators

Indicator	Color	Status	Description
Running indicator	Green	Flashing once every 1s	The receiving card is functioning normally. Ethernet cable connection is normal, and video source input is available.
		Flashing once every 3s	Ethernet cable connection is abnormal.
		Flashing 3 times every 0.5s	Ethernet cable connection is normal, but no video source input is available.
		Flashing once every 0.2s	The receiving card failed to load the program in the application area and is now using the backup program.
		Flashing 8 times every 0.5s	A redundancy switchover occurred on the Ethernet port and the loop backup has taken effect.
Power indicator	Red	Always on	The power input is normal.

Power cord connection instructions: Please calculate and select the appropriate model of distribution box or socket according to the maximum power consumption. Please consult your electrician or distribution cabinet manufacturer for specific selection scheme. The input voltage of the cabinet is 100-240V/AC. The 3X2.5mm²/14awg power cable is used from the distribution box to the cabinet. Please confirm the input voltage, The number of cabinets loaded on each power cable will be different upon different voltages and product models. (Please feel free to contact our after-sales service department if you cannot confirm).

Data and power wiring schematics are shown below:

4.1 Power Supply Wiring

When the input voltage is 220V, each power cable can carry up to 28 cabinets. When the input voltage is 110V, each power cable can carry up to 14 cabinets. the cabinets are connected with power cables of connecting cabinets, and then connect the distribution box

or socket to the bottom of cabinet with 3 x 2.5mm²/14awg power cables.

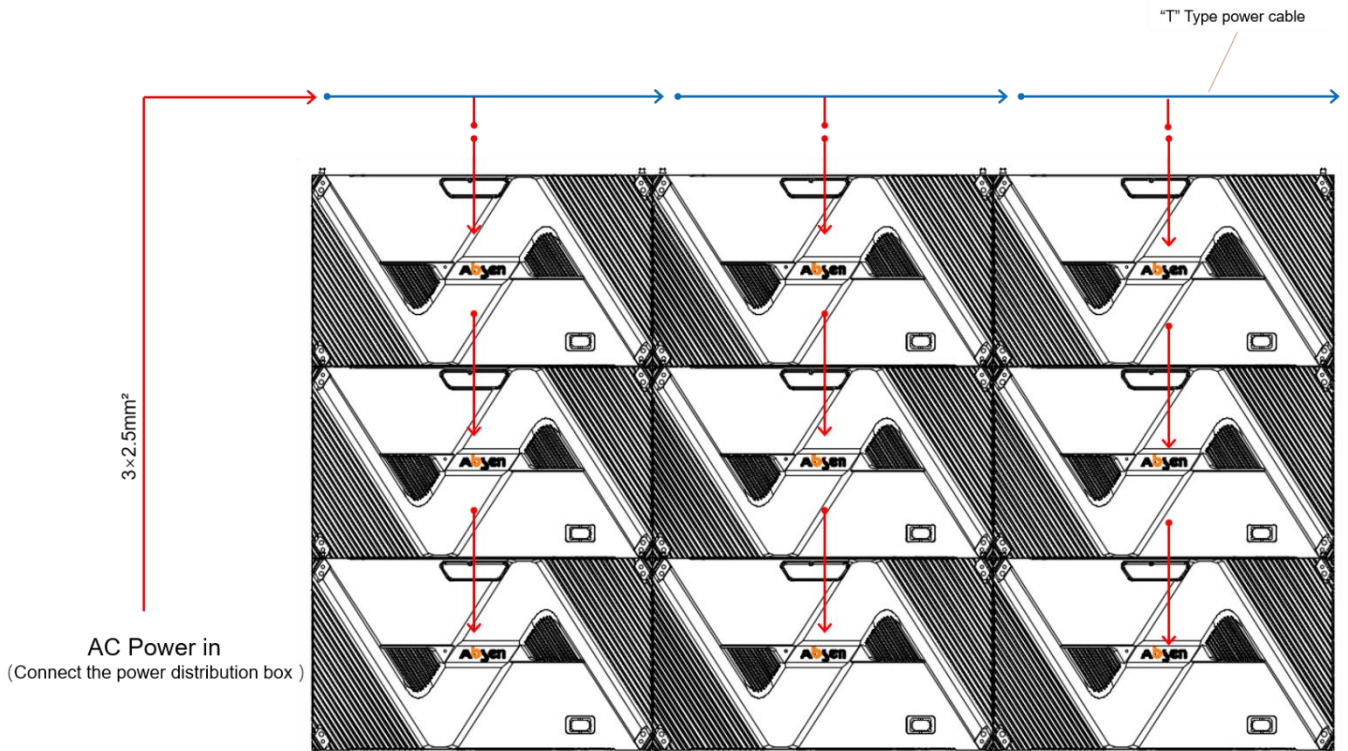

4.2 Signal Cable Wiring

The signal cable uses RJ45 CAT5 network cable, and the network cable interface of the cabinet can be used for input and output. For the "S" type of up-down connection, please calculate the resolution according to the pixels of each cabinet and connect the signal cables according to the loading range of the controller.

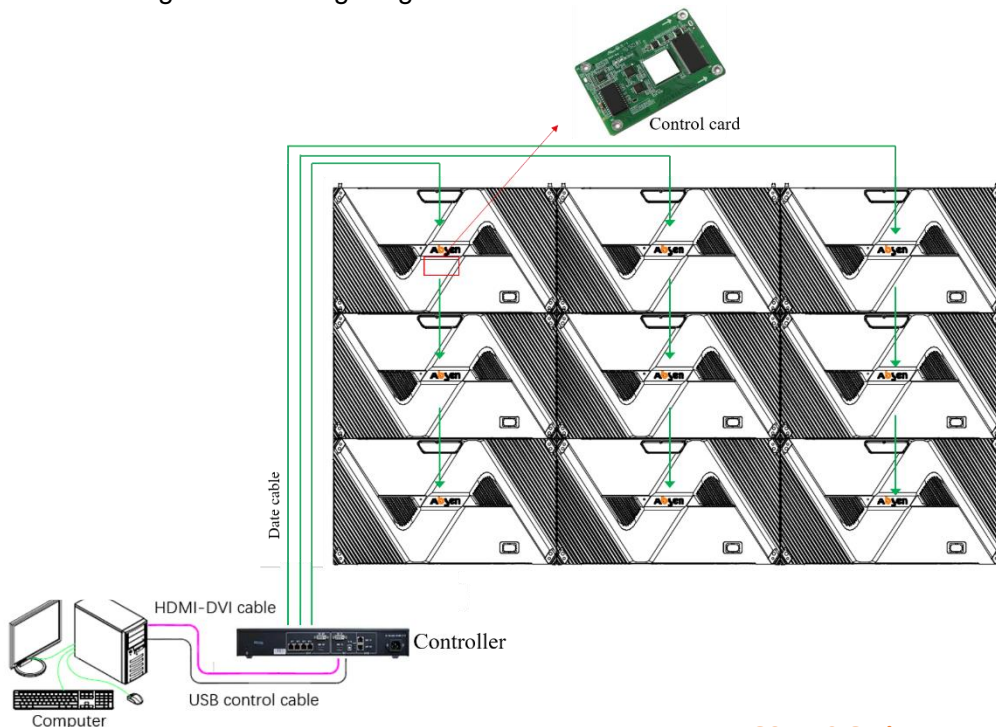

Usually led video wall consists of three important parts.

1. Computer: Send the video source to the video controller through the HDMI cable or DVI cable. The LED cabinet does not display images by itself and requires video source input.
2. Controller: The controller mainly converts the video signal into a signal that can be recognized by the LED cabinet , and can config the LED cabinet through the controller, including the adjustment of display parameters such as brightness, color temperature, contrast, and the splicing of the LED cabinet .
3. LED cabinet : Each LED cabinet contains a control card and a HUB card. The control card receives the signal from the controller and processes the data to controlling each LED pixel. The HUB card plays the role of signal distribution.

Note: The range of loaded pixels of each net port cannot exceed 655360 points (as shown in the following figure)

This product cannot store or display video content solely on itself. To perform normal work , the screen requires video source from the output device such as PC, laptop, media player, etc. and one or more controller to receive and feed the source to it.



4.3 The test of setting up an electric circuit

After the cabinet connection is completed, please use a multimeter to measure whether there is short circuit at the AC input (L/N/PE) and DC output (VCC/GND) of the power supply. If a short circuit is found, please check the circuit carefully. After ensuring the cable is normal, switch on the power to electrify the cabinets to work.

Note: Please refer to the software user manual for software operation.

5. Maintenance

5.1 Tool preparation

	Tools	Function	Picture
Maintenance tool list	Front maintenance tool	Install/Remove LED Module	
	PH2 Phillips screwdriver	Remove/install the screws for the HUB, receiving card and power supply	
	Multimeter	Measuring power supply system	

5.2 Maintenance instructions

5.2.1 module maintenance

KLCOB V2 series modules can be quickly removed using passive front maintenance.

Open the handle of the front maintenance tool, place the front maintenance tool on the surface of the faulty module to be taken out, pull up the handle of the front maintenance tool, and then gently pull the maintenance tool outward to take it out module.



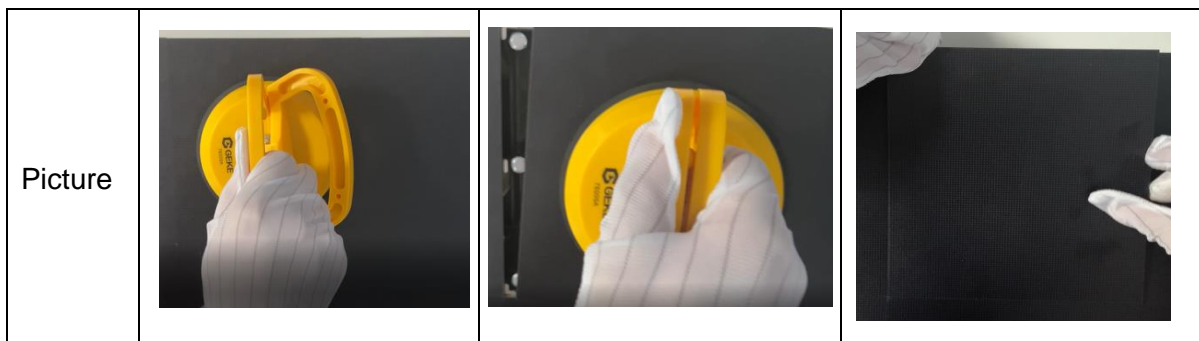

Note: Before maintaining the module, it is necessary to use a dust-free cloth to clean the dust on the surface of the maintenance tool.



Steps	<p>❶ Confirm the location of the faulty module and place the front maintenance tool in the middle of the faulty module</p>	<p>❷ Pull up the handle of the maintenance tool, gently pull the maintenance tool outward, and take out the module</p>	<p>❸ Install the spare module on the screen.</p>
-------	--	--	--

5.2.2 HUB/Receiving card /Power maintenance

Use the maintenance tool to remove the module on the faulty panel, and then use a screwdriver to remove the screw fixing the HUB board for replacement

<p>HUB board maintenance</p> <p>❶ After removing the module with the maintenance tool, remove the current equalizing wire on the HUB board</p>	<p>Picture</p> 
<p>❷ Use a PH2 Phillips screwdriver to remove the screws fixing the HUB board and replace the faulty HUB board</p>	
<p>Receiving card maintenance</p> <p>Remove the HUB board, the receiving card is on the back of the HUB board, remove the screws of the receiving card for maintenance</p>	<p>Picture</p> 
<p>Power supply maintenance</p> <p>❶ After removing the module with the maintenance tool, remove the current equalizing wire on the power supply</p>	<p>Picture</p> 

<p>② Use a PH2 Phillips screwdriver to remove the fixing power supply screw to directly replace the faulty power supply</p>	
---	--

5.2.3 Precautions for use

1. Pay attention to anti-static when touching LED light boards and panels, and do the following effective protection:
 - a. Wear a grounded electrostatic wrist strap or electrostatic gloves;
 - b. The screen is strictly grounded, and the grounding resistance is required to be ≤ 10 ohms, and a point inspection is carried out every six months;
2. When cleaning the surface of the lamp panel, do not use unknown chemical liquids, but use a clean dust-free or clean water damp cloth to wipe lightly;
3. The distribution box is required to have protective facilities such as surge protectors.

6. Common faults and troubleshooting

No.	Common faults	Solution
1	Some modules are black	1. Check whether the power plug of the corresponding module is tightly inserted;
		2. Check whether the power cable of the corresponding module is burnt out;
		3. Check whether the switch power supply of the corresponding module has no output;
		4. Check whether the flat cable of the corresponding module is malfunctioning;
		5. Replace the flat cable of the corresponding module;
		6. Replace the module;
		7. Replace the receiving card;
		8. Send rcfg file;
2	The whole screen is black	1. Check whether the screen power is on;
		2. Check whether the DVI cable or HDMI cable is loose;
		3. Check whether the main data cable is well inserted;
		4. Check whether the controller is powered on and whether the running indicator is flashing;
		5. Replace the controller;
		6. Connecting the computer to an LCD display, check whether there is output on video card;
		7. Update the video card driver;
		8. Replace the computer;
3	Screen show scrambled image	1. Check whether the power plug of the receiving card is well inserted;

		2. Check whether the power cable of the receiving card is burnt out;
		3. Check whether the power supply has no output;
		4. Check the data cable of the receiving card;
		5. Replace the data cable;
		6. Send the rcfg file;
		7. Upgrade the firmware version of the receiving card;
		8. Replace the receiving card;
4	Chromatic aberration between modules	1. Check whether the module power plug is well plugged;
		3. Check whether the main data cable is well inserted;
		4. Check whether the controller is powered on and whether the running indicator is flashing;
		4. Replace the module;
		5. Replace the receiving card;
5	All panels display the same content	1. Set the screen connection on software;
		2. Check whether the data port is wrong.
6	No control system detected	1. Check the USB cable;
		2. Check whether the computer USB port is malfunctioning;
		3. Update the USB driver;
		4. Replace the USB cable;
		5. Replace the controller;
7	No multi-function card detected	1. Check whether the distribution box is in the automatic state;
		2. Check whether the multi-function card is powered;
		3. Replace the power supply of the multi-function card;
		4. Check whether the main data cable is inserted into the wrong data port;
		5. Check whether the controller data port is malfunctioning;
		6. Re-add the multi-function card;
		7. Replace the multi-function card;
		8. Replace the controller ;
8	No full screen display	1. Check whether the setting of the playback window is normal;
		2. Check the output resolution of the video processor;
		3. Check the output window of the video processor;



Check for Power Supply Short Circuit

After completing the cabinet wiring, please use a multimeter to check if there is any short circuit at the AC input power supply (L / N / PE) and DC output terminal (VCC / GND). If there is a short circuit, please carefully investigate the wirings. Make sure all wirings are normal, and only then connect power to operate the unit.

All rights reserved by Shenzhen Absen Optoelectronic Co., Ltd.

Shenzhen Absen Optoelectronic Co., Ltd. reserves the rights to modify contents without any further notice.



Shenzhen Absen Optoelectronic Co., Ltd.
18-20F Building 3A, Cloud Park, Bantian, Longgang
District, Shenzhen 518129, P.R.China
T: +86-755-89747399 E: absen@absen.com
F: +86-755-89747599 W: www.absen.com

Absen Inc.
7120 Lake Ellenor Drive, Orlando,
FL 32809, USA
T: +1-407-203-8870 E: info@usabsen.com
F: +1-407-203-8873 W: www.usabsen.com

Absen GmbH
Eisenstraße 5, 65428 Rüsselsheim a.M.,
Germany
T: +49 (0) 6142 78935-0 E: europe@absen.com
F: +49 (0) 6142 78935-29 W: www.absen-europe.com